

<http://www.EmbeddedDataSystems.com>

FEATURES

- Four & Eight high precision 0 to 10V input channels available
- Inputs are static protected
- Inputs have minimum, maximum and alarms
- Compatible with all EDS and Maxim 1-Wire® bus masters
- Uses 1-Wire communication protocol
- Optional Relay may be controlled independently or by alarm status
- LED may be controlled independently or by alarm status
- Supports Conditional Search with user-selectable conditions
- Automatic unique 64-Bit device addressing
- Applications include thermostatic controls, industrial systems, flow meters, consumer products, or any system in which discrete control or monitoring is necessary



**OW-IO-AI8-10V Eight Channel Input
With & Without Optional Relay**

DESCRIPTION

The EDS 1-Wire 0 to 10V Analog Input Devices offer an innovative way to monitor up to 8 analog points. In addition to the current reading, each point maintains a minimum value and a maximum value. High/low alarms may also be set independently for each input.

The 1-Wire Analog Input also includes an LED and conditional search support. Additionally, an optional latching relay provides further flexibility for alarm notifications and control applications. These features combine to offer a flexible and efficient system for monitoring and controlling numerous data points throughout a 1-Wire network. The conditional search support allows a host adapter to quickly identify whether any alarm parameters have been met; and the LED and optional latching relay can be configured to behave in a variety of ways:

- Activate when an alarm becomes active and automatically deactivate when the alarm is cleared
- Activate when within alarm parameters and deactivate when within normal range
- Independently controlled

The nearly instantaneous automated responses made by the LED and optional relay allow appropriate reactions (activate fan/alarm siren/etc) to occur before the monitoring application is even aware of an alarm. The 1-Wire Analog Input has been designed to simplify the reading and controlling process; and therefore any general-purpose 1-Wire host adapter is able to read the analog points.

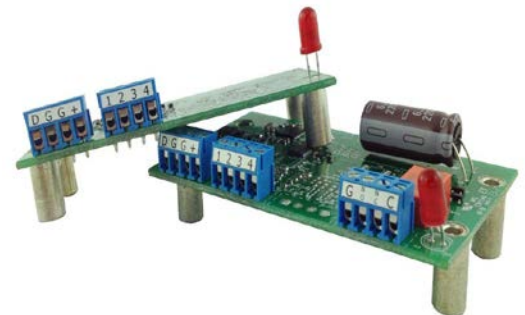

**OW-IO-AI4-10V Four Channel Input
With & Without Optional Relay**

MEMORY MAP

The Analog Inputs memory consists of five 32 bytes pages, which are updated in real-time. The majority of memory is read only. However, page 4 and portions of page 3 are read/write.

Page 0

Addr	b7	b6	b5	b4	b3	b2	b1	b0		
0 - 27	-	-	-	-	-	-	-	-	Tag	R
28	2^3	2^2	2^1	2^0	2^3	2^2	2^1	2^0	Version, low	R
29	2^3	2^2	2^1	2^0	2^3	2^2	2^1	2^0	Version, high	R
30	2^7	2^6	2^5	2^4	2^3	2^2	2^1	2^0	ID, low	R
31	2^{15}	2^{14}	2^{13}	2^{12}	2^{11}	2^{10}	2^9	2^8	ID, high	R

Page 1 – Octal Input

Addr	b7	b6	b5	b4	b3	b2	b1	b0		
32	2^7	2^6	2^5	2^4	2^3	2^2	2^1	2^0	ID, low	R
33	2^{15}	2^{14}	2^{13}	2^{12}	2^{11}	2^{10}	2^9	2^8	ID, high	R
34										R
35										R
36										R
37										R
38										R
39										R
40										R
41							LED	Rly	Relay / LED State	R
42	low 4	high 4	low 3	high 3	low 2	high 2	low 1	high 1	Alarm states	R
43	low 8	high 8	low 7	high 7	low 6	high 6	low 5	high 5		R
44	2^7	2^6	2^5	2^4	2^3	2^2	2^1	2^0	Seconds counter	R
45	2^{15}	2^{14}	2^{13}	2^{12}	2^{11}	2^{10}	2^9	2^8	Seconds counter	R
46	2^{23}	2^{22}	2^{21}	2^{20}	2^{19}	2^{18}	2^{17}	2^{16}	Seconds counter	R
47	2^{31}	2^{30}	2^{29}	2^{28}	2^{27}	2^{26}	2^{25}	2^{24}	Seconds counter	R
48	2^{-4}	2^{-5}	2^{-6}	2^{-7}	2^{-8}	2^{-9}	2^{-10}	2^{-11}	Level 1	R
49	2^4	2^3	2^2	2^1	2^0	2^{-1}	2^{-2}	2^{-3}		R
50	2^{-4}	2^{-5}	2^{-6}	2^{-7}	2^{-8}	2^{-9}	2^{-10}	2^{-11}	Level 2	R
51	2^4	2^3	2^2	2^1	2^0	2^{-1}	2^{-2}	2^{-3}		R
52	2^{-4}	2^{-5}	2^{-6}	2^{-7}	2^{-8}	2^{-9}	2^{-10}	2^{-11}	Level 3	R
53	2^4	2^3	2^2	2^1	2^0	2^{-1}	2^{-2}	2^{-3}		R
54	2^{-4}	2^{-5}	2^{-6}	2^{-7}	2^{-8}	2^{-9}	2^{-10}	2^{-11}	Level 4	R
55	2^4	2^3	2^2	2^1	2^0	2^{-1}	2^{-2}	2^{-3}		R
56	2^{-4}	2^{-5}	2^{-6}	2^{-7}	2^{-8}	2^{-9}	2^{-10}	2^{-11}	Level 5	R
57	2^4	2^3	2^2	2^1	2^0	2^{-1}	2^{-2}	2^{-3}		R
58	2^{-4}	2^{-5}	2^{-6}	2^{-7}	2^{-8}	2^{-9}	2^{-10}	2^{-11}	Level 6	R
59	2^4	2^3	2^2	2^1	2^0	2^{-1}	2^{-2}	2^{-3}		R
60	2^{-4}	2^{-5}	2^{-6}	2^{-7}	2^{-8}	2^{-9}	2^{-10}	2^{-11}	Level 7	R
61	2^4	2^3	2^2	2^1	2^0	2^{-1}	2^{-2}	2^{-3}		R
62	2^{-4}	2^{-5}	2^{-6}	2^{-7}	2^{-8}	2^{-9}	2^{-10}	2^{-11}	Level 8	R
63	2^4	2^3	2^2	2^1	2^0	2^{-1}	2^{-2}	2^{-3}		R

Page 2 – Octal Input

Addr	b7	b6	b5	b4	b3	b2	b1	b0		
64	2^{-4}	2^{-5}	2^{-6}	2^{-7}	2^{-8}	2^{-9}	2^{-10}	2^{-11}	Min 1	R
65	2^4	2^3	2^2	2^1	2^0	2^{-1}	2^{-2}	2^{-3}		R
66	2^{-4}	2^{-5}	2^{-6}	2^{-7}	2^{-8}	2^{-9}	2^{-10}	2^{-11}	Min 2	R
67	2^4	2^3	2^2	2^1	2^0	2^{-1}	2^{-2}	2^{-3}		R

68	2 ⁻⁴	2 ⁻⁵	2 ⁻⁶	2 ⁻⁷	2 ⁻⁸	2 ⁻⁹	2 ⁻¹⁰	2 ⁻¹¹	Min 3	R
69	2 ⁴	2 ³	2 ²	2 ¹	2 ⁰	2 ⁻¹	2 ⁻²	2 ⁻³		R
70	2 ⁻⁴	2 ⁻⁵	2 ⁻⁶	2 ⁻⁷	2 ⁻⁸	2 ⁻⁹	2 ⁻¹⁰	2 ⁻¹¹	Min 4	R
71	2 ⁴	2 ³	2 ²	2 ¹	2 ⁰	2 ⁻¹	2 ⁻²	2 ⁻³		R
72	2 ⁻⁴	2 ⁻⁵	2 ⁻⁶	2 ⁻⁷	2 ⁻⁸	2 ⁻⁹	2 ⁻¹⁰	2 ⁻¹¹	Min 5	R
73	2 ⁴	2 ³	2 ²	2 ¹	2 ⁰	2 ⁻¹	2 ⁻²	2 ⁻³		R
74	2 ⁻⁴	2 ⁻⁵	2 ⁻⁶	2 ⁻⁷	2 ⁻⁸	2 ⁻⁹	2 ⁻¹⁰	2 ⁻¹¹	Min 6	R
75	2 ⁴	2 ³	2 ²	2 ¹	2 ⁰	2 ⁻¹	2 ⁻²	2 ⁻³		R
76	2 ⁻⁴	2 ⁻⁵	2 ⁻⁶	2 ⁻⁷	2 ⁻⁸	2 ⁻⁹	2 ⁻¹⁰	2 ⁻¹¹	Min 7	R
77	2 ⁴	2 ³	2 ²	2 ¹	2 ⁰	2 ⁻¹	2 ⁻²	2 ⁻³		R
78	2 ⁻⁴	2 ⁻⁵	2 ⁻⁶	2 ⁻⁷	2 ⁻⁸	2 ⁻⁹	2 ⁻¹⁰	2 ⁻¹¹	Min 8	R
79	2 ⁴	2 ³	2 ²	2 ¹	2 ⁰	2 ⁻¹	2 ⁻²	2 ⁻³		R
80	2 ⁻⁴	2 ⁻⁵	2 ⁻⁶	2 ⁻⁷	2 ⁻⁸	2 ⁻⁹	2 ⁻¹⁰	2 ⁻¹¹	Max 1	R
81	2 ⁴	2 ³	2 ²	2 ¹	2 ⁰	2 ⁻¹	2 ⁻²	2 ⁻³		R
82	2 ⁻⁴	2 ⁻⁵	2 ⁻⁶	2 ⁻⁷	2 ⁻⁸	2 ⁻⁹	2 ⁻¹⁰	2 ⁻¹¹	Max 2	R
83	2 ⁴	2 ³	2 ²	2 ¹	2 ⁰	2 ⁻¹	2 ⁻²	2 ⁻³		R
84	2 ⁻⁴	2 ⁻⁵	2 ⁻⁶	2 ⁻⁷	2 ⁻⁸	2 ⁻⁹	2 ⁻¹⁰	2 ⁻¹¹	Max 3	R
85	2 ⁴	2 ³	2 ²	2 ¹	2 ⁰	2 ⁻¹	2 ⁻²	2 ⁻³		R
86	2 ⁻⁴	2 ⁻⁵	2 ⁻⁶	2 ⁻⁷	2 ⁻⁸	2 ⁻⁹	2 ⁻¹⁰	2 ⁻¹¹	Max 4	R
87	2 ⁴	2 ³	2 ²	2 ¹	2 ⁰	2 ⁻¹	2 ⁻²	2 ⁻³		R
88	2 ⁻⁴	2 ⁻⁵	2 ⁻⁶	2 ⁻⁷	2 ⁻⁸	2 ⁻⁹	2 ⁻¹⁰	2 ⁻¹¹	Max 5	R
89	2 ⁴	2 ³	2 ²	2 ¹	2 ⁰	2 ⁻¹	2 ⁻²	2 ⁻³		R
90	2 ⁻⁴	2 ⁻⁵	2 ⁻⁶	2 ⁻⁷	2 ⁻⁸	2 ⁻⁹	2 ⁻¹⁰	2 ⁻¹¹	Max 6	R
91	2 ⁴	2 ³	2 ²	2 ¹	2 ⁰	2 ⁻¹	2 ⁻²	2 ⁻³		R
92	2 ⁻⁴	2 ⁻⁵	2 ⁻⁶	2 ⁻⁷	2 ⁻⁸	2 ⁻⁹	2 ⁻¹⁰	2 ⁻¹¹	Max 7	R
93	2 ⁴	2 ³	2 ²	2 ¹	2 ⁰	2 ⁻¹	2 ⁻²	2 ⁻³		R
94	2 ⁻⁴	2 ⁻⁵	2 ⁻⁶	2 ⁻⁷	2 ⁻⁸	2 ⁻⁹	2 ⁻¹⁰	2 ⁻¹¹	Max 8	R
95	2 ⁴	2 ³	2 ²	2 ¹	2 ⁰	2 ⁻¹	2 ⁻²	2 ⁻³		R

Page 3 – Octal Input

Addr	b7	b6	b5	b4	b3	b2	b1	b0		
96										R
97										R
98										R
99										R
100										R
101										R
102										R
103										R
104										R
105										R
106										R
107										R
108										R
109										R
110										R
111										R
112	2 ⁻⁴	2 ⁻⁵	2 ⁻⁶	2 ⁻⁷	2 ⁻⁸	2 ⁻⁹	2 ⁻¹⁰	2 ⁻¹¹	Alarm high 1	RW
113	2 ⁴	2 ³	2 ²	2 ¹	2 ⁰	2 ⁻¹	2 ⁻²	2 ⁻³		RW
114	2 ⁻⁴	2 ⁻⁵	2 ⁻⁶	2 ⁻⁷	2 ⁻⁸	2 ⁻⁹	2 ⁻¹⁰	2 ⁻¹¹	Alarm low 1	RW
115	2 ⁴	2 ³	2 ²	2 ¹	2 ⁰	2 ⁻¹	2 ⁻²	2 ⁻³		RW
116	2 ⁻⁴	2 ⁻⁵	2 ⁻⁶	2 ⁻⁷	2 ⁻⁸	2 ⁻⁹	2 ⁻¹⁰	2 ⁻¹¹	Alarm high 2	RW
117	2 ⁴	2 ³	2 ²	2 ¹	2 ⁰	2 ⁻¹	2 ⁻²	2 ⁻³		RW

118	2 ⁻⁴	2 ⁻⁵	2 ⁻⁶	2 ⁻⁷	2 ⁻⁸	2 ⁻⁹	2 ⁻¹⁰	2 ⁻¹¹	Alarm low 2	RW
119	2 ⁻⁴	2 ⁻³	2 ⁻²	2 ⁻¹	2 ⁰	2 ⁻¹	2 ⁻²	2 ⁻³		RW
120	2 ⁻⁴	2 ⁻⁵	2 ⁻⁶	2 ⁻⁷	2 ⁻⁸	2 ⁻⁹	2 ⁻¹⁰	2 ⁻¹¹	Alarm high 3	RW
121	2 ⁻⁴	2 ⁻³	2 ⁻²	2 ⁻¹	2 ⁰	2 ⁻¹	2 ⁻²	2 ⁻³		RW
122	2 ⁻⁴	2 ⁻⁵	2 ⁻⁶	2 ⁻⁷	2 ⁻⁸	2 ⁻⁹	2 ⁻¹⁰	2 ⁻¹¹	Alarm low 3	RW
123	2 ⁻⁴	2 ⁻³	2 ⁻²	2 ⁻¹	2 ⁰	2 ⁻¹	2 ⁻²	2 ⁻³		RW
124	2 ⁻⁴	2 ⁻⁵	2 ⁻⁶	2 ⁻⁷	2 ⁻⁸	2 ⁻⁹	2 ⁻¹⁰	2 ⁻¹¹	Alarm high 4	RW
125	2 ⁻⁴	2 ⁻³	2 ⁻²	2 ⁻¹	2 ⁰	2 ⁻¹	2 ⁻²	2 ⁻³		RW
126	2 ⁻⁴	2 ⁻⁵	2 ⁻⁶	2 ⁻⁷	2 ⁻⁸	2 ⁻⁹	2 ⁻¹⁰	2 ⁻¹¹	Alarm low 4	RW
127	2 ⁻⁴	2 ⁻³	2 ⁻²	2 ⁻¹	2 ⁰	2 ⁻¹	2 ⁻²	2 ⁻³		RW

Page 4 – Octal Input

Addr	b7	b6	b5	b4	b3	b2	b1	b0		
128	2 ⁻⁴	2 ⁻⁵	2 ⁻⁶	2 ⁻⁷	2 ⁻⁸	2 ⁻⁹	2 ⁻¹⁰	2 ⁻¹¹	Alarm high 5	RW
129	2 ⁻⁴	2 ⁻³	2 ⁻²	2 ⁻¹	2 ⁰	2 ⁻¹	2 ⁻²	2 ⁻³		RW
130	2 ⁻⁴	2 ⁻⁵	2 ⁻⁶	2 ⁻⁷	2 ⁻⁸	2 ⁻⁹	2 ⁻¹⁰	2 ⁻¹¹	Alarm low 5	RW
131	2 ⁻⁴	2 ⁻³	2 ⁻²	2 ⁻¹	2 ⁰	2 ⁻¹	2 ⁻²	2 ⁻³		RW
132	2 ⁻⁴	2 ⁻⁵	2 ⁻⁶	2 ⁻⁷	2 ⁻⁸	2 ⁻⁹	2 ⁻¹⁰	2 ⁻¹¹	Alarm high 6	RW
133	2 ⁻⁴	2 ⁻³	2 ⁻²	2 ⁻¹	2 ⁰	2 ⁻¹	2 ⁻²	2 ⁻³		RW
134	2 ⁻⁴	2 ⁻⁵	2 ⁻⁶	2 ⁻⁷	2 ⁻⁸	2 ⁻⁹	2 ⁻¹⁰	2 ⁻¹¹	Alarm low 6	RW
135	2 ⁻⁴	2 ⁻³	2 ⁻²	2 ⁻¹	2 ⁰	2 ⁻¹	2 ⁻²	2 ⁻³		RW
136	2 ⁻⁴	2 ⁻⁵	2 ⁻⁶	2 ⁻⁷	2 ⁻⁸	2 ⁻⁹	2 ⁻¹⁰	2 ⁻¹¹	Alarm high 7	RW
137	2 ⁻⁴	2 ⁻³	2 ⁻²	2 ⁻¹	2 ⁰	2 ⁻¹	2 ⁻²	2 ⁻³		RW
138	2 ⁻⁴	2 ⁻⁵	2 ⁻⁶	2 ⁻⁷	2 ⁻⁸	2 ⁻⁹	2 ⁻¹⁰	2 ⁻¹¹	Alarm low 7	RW
139	2 ⁻⁴	2 ⁻³	2 ⁻²	2 ⁻¹	2 ⁰	2 ⁻¹	2 ⁻²	2 ⁻³		RW
140	2 ⁻⁴	2 ⁻⁵	2 ⁻⁶	2 ⁻⁷	2 ⁻⁸	2 ⁻⁹	2 ⁻¹⁰	2 ⁻¹¹	Alarm high 8	RW
141	2 ⁻⁴	2 ⁻³	2 ⁻²	2 ⁻¹	2 ⁰	2 ⁻¹	2 ⁻²	2 ⁻³		RW
142	2 ⁻⁴	2 ⁻⁵	2 ⁻⁶	2 ⁻⁷	2 ⁻⁸	2 ⁻⁹	2 ⁻¹⁰	2 ⁻¹¹	Alarm low 8	RW
143	2 ⁻⁴	2 ⁻³	2 ⁻²	2 ⁻¹	2 ⁰	2 ⁻¹	2 ⁻²	2 ⁻³		RW
144										RW
145										RW
146										RW
147										RW
148										RW
149										RW
150										RW
151										RW
152										RW
153										RW
154	low 4	high 4	low 3	high 3	low 2	high 2	low 1	high 1	Conditional search	RW
155	low 8	high 8	low 7	high 7	low 6	high 6	low 5	high 5		RW
156										RW
157										RW
158					L1	L0	R1	R0	Relay / LED Function*	RW
159							LED	Rly	Relay / LED State*	RW

* If the relay is not populated the bits pertaining to the Relay Function may be ignored.

Page 1 – Quad Input

Addr	b7	b6	b5	b4	b3	b2	b1	b0		
32	2 ⁷	2 ⁶	2 ⁵	2 ⁴	2 ³	2 ²	2 ¹	2 ⁰	ID, low	R
33	2 ¹⁵	2 ¹⁴	2 ¹³	2 ¹²	2 ¹¹	2 ¹⁰	2 ⁹	2 ⁸	ID, high	R

34							LED	Rly	Relay / LED State	R
35	lo 4	hi 4	lo 3	hi 3	lo 2	hi 2	lo 1	hi 1	Alarm states	R
36	2^7	2^6	2^5	2^4	2^3	2^2	2^1	2^0	Seconds counter	R
37	2^{15}	2^{14}	2^{13}	2^{12}	2^{11}	2^{10}	2^9	2^8	Seconds counter	R
38	2^{23}	2^{22}	2^{21}	2^{20}	2^{19}	2^{18}	2^{17}	2^{16}	Seconds counter	R
39	2^{31}	2^{30}	2^{29}	2^{28}	2^{27}	2^{26}	2^{25}	2^{24}	Seconds counter	R
40	2^{-4}	2^{-5}	2^{-6}	2^{-7}	2^{-8}	2^{-9}	2^{-10}	2^{-11}	Level 1	R
41	2^4	2^3	2^2	2^1	2^0	2^{-1}	2^{-2}	2^{-3}		R
42	2^{-4}	2^{-5}	2^{-6}	2^{-7}	2^{-8}	2^{-9}	2^{-10}	2^{-11}	Level 2	R
43	2^4	2^3	2^2	2^1	2^0	2^{-1}	2^{-2}	2^{-3}		R
44	2^{-4}	2^{-5}	2^{-6}	2^{-7}	2^{-8}	2^{-9}	2^{-10}	2^{-11}	Level 3	R
45	2^4	2^3	2^2	2^1	2^0	2^{-1}	2^{-2}	2^{-3}		R
46	2^{-4}	2^{-5}	2^{-6}	2^{-7}	2^{-8}	2^{-9}	2^{-10}	2^{-11}	Level 4	R
47	2^4	2^3	2^2	2^1	2^0	2^{-1}	2^{-2}	2^{-3}		R
48	2^{-4}	2^{-5}	2^{-6}	2^{-7}	2^{-8}	2^{-9}	2^{-10}	2^{-11}	Min 1	R
49	2^4	2^3	2^2	2^1	2^0	2^{-1}	2^{-2}	2^{-3}		R
50	2^{-4}	2^{-5}	2^{-6}	2^{-7}	2^{-8}	2^{-9}	2^{-10}	2^{-11}	Min 2	R
51	2^4	2^3	2^2	2^1	2^0	2^{-1}	2^{-2}	2^{-3}		R
52	2^{-4}	2^{-5}	2^{-6}	2^{-7}	2^{-8}	2^{-9}	2^{-10}	2^{-11}	Min 3	R
53	2^4	2^3	2^2	2^1	2^0	2^{-1}	2^{-2}	2^{-3}		R
54	2^{-4}	2^{-5}	2^{-6}	2^{-7}	2^{-8}	2^{-9}	2^{-10}	2^{-11}	Min 4	R
55	2^4	2^3	2^2	2^1	2^0	2^{-1}	2^{-2}	2^{-3}		R
56	2^{-4}	2^{-5}	2^{-6}	2^{-7}	2^{-8}	2^{-9}	2^{-10}	2^{-11}	Max 1	R
57	2^4	2^3	2^2	2^1	2^0	2^{-1}	2^{-2}	2^{-3}		R
58	2^{-4}	2^{-5}	2^{-6}	2^{-7}	2^{-8}	2^{-9}	2^{-10}	2^{-11}	Max 2	R
59	2^4	2^3	2^2	2^1	2^0	2^{-1}	2^{-2}	2^{-3}		R
60	2^{-4}	2^{-5}	2^{-6}	2^{-7}	2^{-8}	2^{-9}	2^{-10}	2^{-11}	Max 3	R
61	2^4	2^3	2^2	2^1	2^0	2^{-1}	2^{-2}	2^{-3}		R
62	2^{-4}	2^{-5}	2^{-6}	2^{-7}	2^{-8}	2^{-9}	2^{-10}	2^{-11}	Max 4	R
63	2^4	2^3	2^2	2^1	2^0	2^{-1}	2^{-2}	2^{-3}		R

Page 2 – Quad Input

Addr	b7	b6	b5	b4	b3	b2	b1	b0		
										R
										R
										R
										R
										R
										R
										R
72	2^{-4}	2^{-5}	2^{-6}	2^{-7}	2^{-8}	2^{-9}	2^{-10}	2^{-11}	Alm high 1	RW

73	2 ⁴	2 ³	2 ²	2 ¹	2 ⁰	2 ⁻¹	2 ⁻²	2 ⁻³		RW
74	2 ⁻⁴	2 ⁻⁵	2 ⁻⁶	2 ⁻⁷	2 ⁻⁸	2 ⁻⁹	2 ⁻¹⁰	2 ⁻¹¹	Alm low 1	RW
75	2 ⁴	2 ³	2 ²	2 ¹	2 ⁰	2 ⁻¹	2 ⁻²	2 ⁻³		RW
76	2 ⁻⁴	2 ⁻⁵	2 ⁻⁶	2 ⁻⁷	2 ⁻⁸	2 ⁻⁹	2 ⁻¹⁰	2 ⁻¹¹	Alm high 2	RW
77	2 ⁴	2 ³	2 ²	2 ¹	2 ⁰	2 ⁻¹	2 ⁻²	2 ⁻³		RW
78	2 ⁻⁴	2 ⁻⁵	2 ⁻⁶	2 ⁻⁷	2 ⁻⁸	2 ⁻⁹	2 ⁻¹⁰	2 ⁻¹¹	Alm low 2	RW
79	2 ⁴	2 ³	2 ²	2 ¹	2 ⁰	2 ⁻¹	2 ⁻²	2 ⁻³		RW
80	2 ⁻⁴	2 ⁻⁵	2 ⁻⁶	2 ⁻⁷	2 ⁻⁸	2 ⁻⁹	2 ⁻¹⁰	2 ⁻¹¹	Alm high 3	RW
81	2 ⁴	2 ³	2 ²	2 ¹	2 ⁰	2 ⁻¹	2 ⁻²	2 ⁻³		RW
82	2 ⁻⁴	2 ⁻⁵	2 ⁻⁶	2 ⁻⁷	2 ⁻⁸	2 ⁻⁹	2 ⁻¹⁰	2 ⁻¹¹	Alm low 3	RW
83	2 ⁴	2 ³	2 ²	2 ¹	2 ⁰	2 ⁻¹	2 ⁻²	2 ⁻³		RW
84	2 ⁻⁴	2 ⁻⁵	2 ⁻⁶	2 ⁻⁷	2 ⁻⁸	2 ⁻⁹	2 ⁻¹⁰	2 ⁻¹¹	Alm high 4	RW
85	2 ⁴	2 ³	2 ²	2 ¹	2 ⁰	2 ⁻¹	2 ⁻²	2 ⁻³		RW
86	2 ⁻⁴	2 ⁻⁵	2 ⁻⁶	2 ⁻⁷	2 ⁻⁸	2 ⁻⁹	2 ⁻¹⁰	2 ⁻¹¹	Alm low 4	RW
87	2 ⁴	2 ³	2 ²	2 ¹	2 ⁰	2 ⁻¹	2 ⁻²	2 ⁻³		RW
88										RW
89										RW
90										RW
91										RW
92	lo 4	hi 4	lo 3	hi 3	lo 2	hi 2	lo 1	hi 1	Conditional search	RW
93										RW
94					L1	L0	R1	R0	Relay / LED Function*	RW
95							LED	Rly	Relay / LED State*	RW

* If the relay is not populated the bits pertaining to the Relay Function may be ignored.

NUMBER FORMAT

Numbers are formatted using a fixed-point scheme where, out of 16 bits, 5 bits represent the number to the left of the decimal point and 11 bits represent it to the right. With this arrangement, numbers can be represented between 0 and 31.9995. No provision is made for negative numbers.

	b7	b6	b5	b4	b3	b2	b1	b0		
	2 ⁻⁴	2 ⁻⁵	2 ⁻⁶	2 ⁻⁷	2 ⁻⁸	2 ⁻⁹	2 ⁻¹⁰	2 ⁻¹¹	0-10V	
	2 ⁴	2 ³	2 ²	2 ¹	2 ⁰	2 ⁻¹	2 ⁻²	2 ⁻³		

The equation to convert the received 16 bit number to a decimal point number is to divide by 2048.

Current in milliamp	Digital Output (binary)	Digital Output (hex)
+20.0	1010 0000 0000 0000	A000h
+10.5	0101 0100 0000 0000	5400h
+1.001*	0000 1000 0000 0010	0802h
+0.5 °C	0000 0100 0000 0000	0400h
0 °C	0000 0000 0000 0000	0000h

*This value is actually 1.0009765625.

INPUTS

Each input maintains 3 parameters: Level, Minimum and Maximum. The 'Level' is the instant reading of the converter. The 'Minimum' and 'Maximum' display the min and max values. The clear alarms command resets these last 2 values.

ALARMS

Alarms are calculated every time a reading is made. If the reading is above the high alarm value, the corresponding high alarm bit is set, and if the reading is below the low alarm value, the low alarm bit is set. Alarm bits can only be cleared by sending the clear alarms command (0x33), which clears all alarm bits. No provision is made to clear individually selected alarm bits.

CONDITIONAL SEARCHES

The device will respond to the conditional search command from a master if any or all of the conditional search bits are set. The conditional search bits are set when an alarm becomes active and are cleared only under program control, by writing to the appropriate bit(s) at location 154 and 155.

SECONDS COUNTER

The 32 bit counter (bytes 44 to 47) is set to zero at power up and increments approximately once per second.

RELAY AND LED

The relay and LED may operate in any of the following modes:

Mode	Bit L1 (LED) or R1 (Relay)	Bit L0 (LED) or R0 (Relay)
(0) On with any alarm, off if no alarms active	0	0
(1) On with any alarm, off when clear alarms command received	0	1
(2) On and Off under command using State bit (address 95)	1	0
(3) Always off	1	1

The relay is a latching relay; it retains its state when power is lost. The states of the relay and LED are stored in non-volatile memory and are restored at power-up. Since the relay is latching, its state remains the same, even when power is removed.

PROGRAMMABLE VALUES

Programmable values are stored in non-volatile memory.

	Factory Default	Minimum Value	Maximum Value
Alarm High	31.000	0.0	31.9995
Alarm Low	0.0	0.0	31.9995
LED Function	2	0	3
Relay Function	2	0	3
LED State	0	0	1
Relay State	0	0	1

1-WIRE COMMUNICATIONS

The device communicates via 1-wire at standard speed only; overdrive is not supported. All memory pages are 32 bytes, CRC16 and a 32 byte scratchpad is used to write data to the device.

ROM Commands

After the bus master has detected a presence pulse, it can issue a ROM command. These commands operate on the unique 64-bit ROM codes of each slave device and allow the master to single out a specific device if many are present on the 1-Wire bus. These commands also allow the master to determine how many and what types of devices are present on the bus or if any device has experienced an alarm condition. There are five ROM commands, and each command is 8 bits long. The ROM commands function the same as on other 1-wire devices. The master device must issue an appropriate ROM command before issuing a function command.

Alarm Search ROM – 0xEC

The operation of this command is identical to the operation of the Search ROM command except that only slaves with a set alarm flag (bytes 154 and 155) will respond. This command allows the master device to determine if any EDS 0 to 10v device is in an alarm. After every Alarm Search cycle (i.e., Alarm Search command followed by data exchange), the bus

master must return to Step 1 (Initialization) in the transaction sequence. See the Operation—Alarm Signaling section for an explanation of alarm flag operation.

Search ROM – 0xF0

When a system is initially powered up, the master must identify the ROM codes of all slave devices on the bus, which allows the master to determine the number of slaves and their device types. The master learns the ROM codes through a process of elimination that requires the master to perform a Search ROM cycle (i.e., Search ROM command followed by data exchange) as many times as necessary to identify all of the slave devices. If there is only one slave on the bus, the simpler Read ROM command (see below) can be used in place of the Search ROM process. For a detailed explanation of the Search ROM procedure, refer to the iButton® Book of Standards at www.maxim-ic.com/ibuttonbook. After every Search ROM cycle, the bus master must return to Step 1 (Initialization) in the transaction sequence.

Match ROM – 0x55

The match ROM command followed by a 64-bit ROM code sequence allows the bus master to address a specific slave device on a multi-drop or single-drop bus. Only the slave that exactly matches the 64-bit ROM code sequence will respond to the function command issued by the master; all other slaves on the bus will wait for a reset pulse.

Skip ROM – 0xCC

The master can use this command to address all devices on the bus simultaneously without sending out any ROM code information. For example, the master can clear all alarming EDS Environmental sensors on the bus perform simultaneous temperature conversions by issuing a Skip ROM command followed by a Clear alarms [0x33] command.

Note that the Read Scratchpad [0xAA] command can follow the Skip ROM command only if there is a single slave device on the bus. In this case, time is saved, by allowing the master to read from the slave without sending the device's 64-bit ROM code. A Skip ROM command followed by a Read Scratchpad command will cause a data collision on the bus if there is more than one slave since multiple devices will attempt to transmit data simultaneously.

Read ROM – 0x33

This command can only be used when there is one slave on the bus. It allows the bus master to read the slave's 64-bit ROM code without using the Search ROM procedure. If this command is used when there is more than one slave present on the bus, a data collision will occur when all the slaves attempt to respond at the same time.

Memory / Control Commands

Write scratchpad – 0x0F
Read scratchpad – 0xAA
Copy scratchpad – 0x55
Read memory no CRC – 0xF0
Read memory with CRC – 0xA5
Clear alarms – 0x33

Write Scratchpad – 0x0F

After issuing the Write Scratchpad command, the master must first provide the 2-byte target address, followed by the data to be written to the scratchpad. The data will be written to the scratchpad starting at the byte offset (T4:T0). The ending offset (E4:E0) will be the byte offset at which the master stops writing data. Only full data bytes are accepted. If the last data byte is incomplete, its content will be ignored.

When executing the Write Scratchpad command, the CRC generator inside the device calculates a CRC of the entire data stream, starting at the command code and ending at the last data byte sent by the master. This CRC is generated using the CRC16 polynomial by first clearing the CRC generator and then shifting in the command code (0Fh) of the Write Scratchpad command, the Target Addresses TA1 and TA2 as supplied by the master and all the data bytes. The master may end the Write Scratchpad command at any time. However, if the ending offset is 1111b, the master may send 16 read time slots and will receive an inverted CRC16 generated by the device.

Read Scratchpad – 0xAA

This command is used to verify scratchpad data and target address. After issuing the Read Scratchpad command, the master begins reading. The first 2 bytes will be the target address. The next byte will be the ending offset/data status byte (E/S) followed by the scratchpad data beginning at the byte offset (T4:T0). Regardless of the actual ending offset, the master may read data until the end of the scratchpad after which it will receive an inverted CRC16 of the command code, Target Addresses TA1 and TA2, the E/S byte, and the scratchpad data starting at the target address. After the CRC is read, the bus master will read logical 1s from the device until a reset pulse is issued.

Copy Scratchpad – 0x55

This command is used to copy data from the scratchpad to the writable memory sections. Applying Copy Scratchpad to the Relay/LED State Byte can control the relay and/or LED provided that functionality has been enabled (see Relay and LED section for details). After issuing the Copy Scratchpad command, the master must provide a 3-byte authorization pattern, which can be obtained by reading the scratchpad for verification. This pattern must exactly match the data contained in the three address registers (TA1, TA2, E/S, in that order). A pattern of alternating 1s and 0s will be transmitted after the data has been copied until the master issues a reset pulse.

The data to be copied is determined by the three address registers. The scratchpad data from the beginning offset through the ending offset will be copied, starting at the target address. Anywhere from 1 to 32 bytes may be copied to memory with this command.

Read Memory no CRC – 0xF0

The Read Memory command may be used to read the entire memory. After issuing the command, the master must provide the 2-byte target address. After the 2 bytes, the master reads data beginning from the target address and may continue until the end of memory, at which point logic 0s will be read. It is important to realize that the target address registers will contain the address provided. The ending offset/data status byte is unaffected.

To safeguard data in the 1-Wire environment when reading and to simultaneously speed up data transfers, it is recommended to make use of the Read Memory with CRC (0xA5) whenever possible. The 16-bit CRC ensures rapid, error-free data transfers that eliminate having to read a page multiple times to verify whether if the received data is correct.

Read Memory with CRC – 0xA5

The Read Memory with CRC command works essentially the same way as the simple Read Memory, except for the 16-bit CRC that the device generates and transmits following the last data byte of a memory page.

After having sent the command code of the Read Memory with CRC command, the bus master sends a 2-byte address (TA1 = T7:T0, TA2 = T15:T8) that indicates a starting byte location. With the subsequent read data time slots the master receives data from the device starting at the initial address and continuing until the end of a 32-byte page is reached. At that point the bus master will send 16 additional read data time slots and receive an inverted 16-bit CRC. With subsequent read data time slots the master will receive data starting at the beginning of the next page followed again by the inverted CRC for that page. This sequence will continue until the bus master resets the device.

With the initial pass through the Read Memory with CRC flow, the 16-bit CRC value is the result of shifting the command byte into the cleared CRC generator followed by the 2 address bytes and the contents of the data memory. Subsequent passes through the Read Memory with CRC flow will generate a 16-bit CRC that is the result of clearing the CRC

generator and then shifting in the contents of the data memory page. After the 16-bit CRC of the last page is read, the bus master will receive logical 0s from the device until a reset pulse is issued.

Clear Alarms – 0x33

The Clear Alarms command is used to set all bits at bytes 42 and 43 to 0. The clearing the alarms has the ability to effect relay state, and LED state depending on the configuration. Additional information on the possible effects is available in *Relay and LED* and/or *Conditional Search* sections of the manual.

Family Code

The family code is 0x7E.

Tag

The tag provides identification for each EDS device type. It consists of three parts: the description, followed by the firmware version number and then the device ID number. The description is the product name as an ASCII text string; i.e. EDS0080 Octal 0-10v In. The firmware version is a 2 byte number provided in BCD format, LSB first. For example: 0x36,0x01 represents the firmware version 1.36. The 2 byte device ID uniquely identifies this device from others with the same family code. This is also presented in BCD format, LSB first. Therefore 0x82,0x00 represents Device ID 0082. The device ID portion of the tag is duplicated at the beginning of the next page so that the user can read one page and retrieve all necessary information to work with the device.

2^3	2^2	2^1	2^0	2^3	2^2	2^1	2^0	Version, low
2^3	2^2	2^1	2^0	2^3	2^2	2^1	2^0	Version, high
2^7	2^6	2^5	2^4	2^3	2^2	2^1	2^0	ID, low
2^{15}	2^{14}	2^{13}	2^{12}	2^{11}	2^{10}	2^9	2^8	ID, high

CURRENT EDS DEVICE IDS

TAG ID	Tag Hex	Tag Bin (LSB first)	Features
EDS0064	0064	0110 0100 0000 0000	Temp
EDS0065	0065	0110 0101 0000 0000	Temp, humidity
EDS0066	0066	0110 0110 0000 0000	Temp, barometric pressure
EDS0067	0067	0110 0111 0000 0000	Temp, light
EDS0068	0068	0110 1000 0000 0000	Temp, humidity, barometric pressure and light
EDS0070	0070	0111 0000 0000 0000	Vibration Sensor
EDS0071	0071	0111 0001 0000 0000	RTD Transmitter 4-Wire
EDS0080	0080	1000 0000 0000 0000	Octal 4-20mA Input
EDS0082	0082	1000 0010 0000 0000	Octal 0-10V Input
EDS0083	0083	1000 0011 0000 0000	Quad 4-20mA Input
EDS0085	0085	1000 0101 0000 0000	Quad 0-10V Input
EDS0090	0090	1001 0000 0000 0000	Octal Discrete I/O
EDS0091	0091	1001 0001 0000 0000	Quad Opto-isolator Input
EDS0092	0092	1001 0010 0000 0000	Quad Relay Output

SPECIFICATIONS

PARAMETER	MIN	TYP	MAX	UNITS
Operating Temperature Range	-40	-	85	°C
Input voltage (before clamping)	-3	-	17	Volts
Input voltage*	0	-	10.5	Volts
Input impedance (-3 to 17 volts)	-	1.24	-	Megaohm
Input impedance (< -3 or > 17 volts)	-	1	-	Megaohm
Converter	16	-	-	Bits
Conversion time (per channel)**	-	120	-	Milliseconds
Precision	0.5	-	-	Percent full scale
Relay Contacts Voltage Rating (DC)	-	-	220	Volts
Relay Contacts Switching Current Rating (DC)	-	-	2	Amps
Relay Contacts Carrying Current Rating (DC)	-	-	4	Amps
Relay Contacts Switching Power Rating (DC, resistive load)	-	-	30	Watts
Relay Contacts Voltage Rating (AC)	-	-	250	Volts
Relay Contacts Switching Current Rating (AC)	-	-	2	Amps
Relay Contacts Carrying Current Rating(AC)	-	-	4	Amps
Relay Switching Power Rating (AC, resistive load)	-	-	62.5	VA
Supply Voltage	4	-	18	Volts DC
Active Current (5 volt supply, LED On)	-	16.2	-	mA
Standby Current (5 volt supply)	-	8.4	-	mA
Enclosure Dimensions (L x W x H)	4.109	2.233	1.594	Inches

*Input voltages outside these ranges are permitted, but they will not read correctly.

**The time from a change in input current to viewing the result on a computer consists of many delays in addition to the conversion time (i.e. time to read the device on the 1-wire bus, computer processing time). Alarms, minimum and maximum values are computed for each reading, so these parameters have an update rate of $4 * 120\text{ms} = 480\text{ms}$ for the Quad Input Device or $8 * 120\text{ms} = 960\text{ms}$ for the Octal Input Device.

INPUT CIRCUIT SCHEMATIC

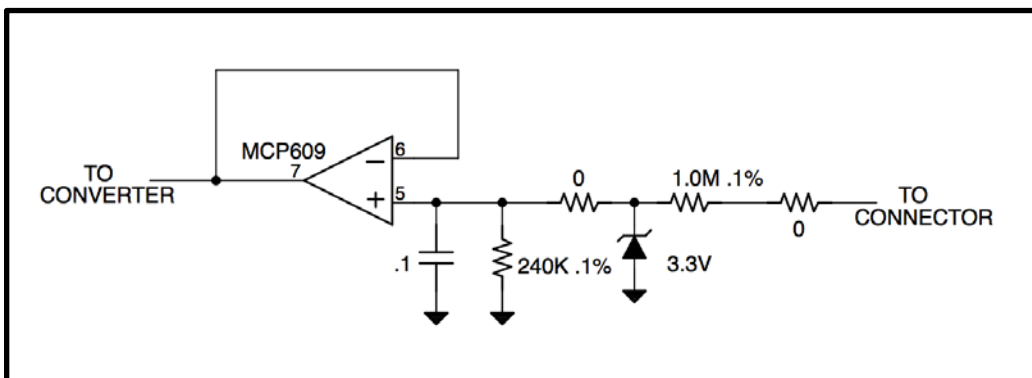

REGULATORY COMPLIANCE

Model OW-IO-AI4-10V and Model OW-IO-AI8-10V:

FEDERAL COMMUNICATIONS COMMISSION (FCC) COMPLIANCE STATEMENT

This device complies with part 15 of the FCC Rules. Operation is subject to the following two conditions: (1) This device may not cause harmful interference, and (2) this device must accept any interference received, including interference that may cause undesired operation.



INDUSTRY CANADA (IC) COMPLIANCE STATEMENT

This Class B digital apparatus complies with Canadian ICES-003-2012.
Cet appareil numérique de la classe B est conforme à la norme NMB-003 du Canada.

Model OW-IO-AI8-10V Only:

EUROPEAN COMMUNITY (EC) DIRECTIVES CONFORMITY

APPLICATION OF COUNCIL DIRECTIVE 2004/108/EC Standard to which Conformity is Declared:

EN 61326-1:2006	(Emmissions)
EN 61326-2-3:2006	(Immunity)
EN 61000-3-2:2006+A1:2009+A2:2009	(Harmonics)
EN 61000-3-3:2008	(Flicker)



Caution: *The manufacturer is not responsible for any radio or television interference caused by using other than recommended cables or by unauthorized changes or modifications to this equipment. Unauthorized changes or modifications could void the user's authority to operate this equipment.*

ACKNOWLEDGEMENTS

1-Wire® is a registered trademark of Maxim Integrated Products, Inc.
iButton® is a registered trademark of Maxim Integrated Products, Inc.